

Understanding Ground Resistance Testing

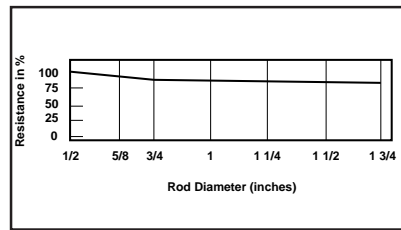
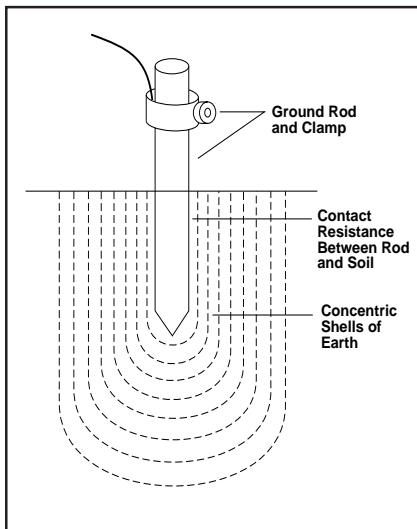
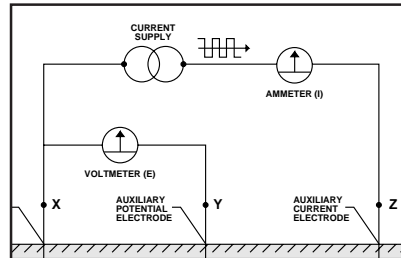
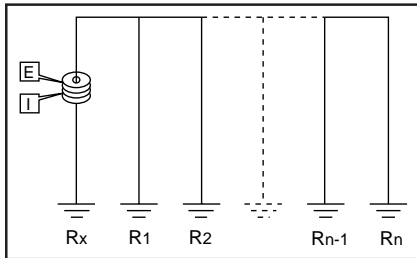

- *Soil Resistivity*
- *Ground Resistance*
- *3 Pole Measurements*
- *4 Pole Measurements*
- *Clamp-on Measurements*

Table of Contents

Soil Resistivity	2
Soil Resistivity Measurements (4-Point Measurement).....	4
Ground Electrodes	6
Ground Resistance Values.....	9
Ground Resistance Testing Principle (Fall of Potential – 3-point Measurement).....	11
Multiple Electrode System	15
Two Point Measurement (Simplified Method)	16
Continuity Measurement	16
Tech Tips.....	17
Touch Potential Measurements.....	20
Clamp-on Ground Resistance Measurement (Models 3710 and 3730)	22
Telecommunications	27
Summary Quiz.....	31
References.....	33
Grounding Nomograph.....	34
Fall of Potential Plot.....	35

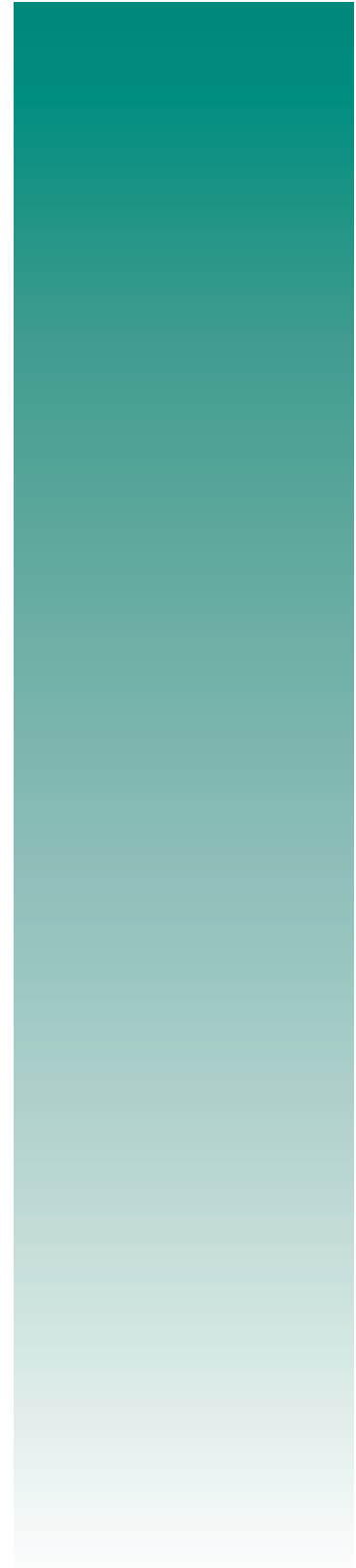

Soil Resistivity

Why Measure Soil Resistivity?

Soil resistivity measurements have a threefold purpose. First, such data are used to make sub-surface geophysical surveys as an aid in identifying ore locations, depth to bedrock and other geological phenomena. Second, resistivity has a direct impact on the degree of corrosion in underground pipelines. A decrease in resistivity relates to an increase in corrosion activity and therefore dictates the protective treatment to be used. Third, soil resistivity directly affects the design of a grounding system, and it is to that task that this discussion is directed. When designing an extensive grounding system, it is advisable to locate the area of lowest soil resistivity in order to achieve the most economical grounding installation.

Effects of Soil Resistivity on Ground Electrode Resistance

Soil resistivity is the key factor that determines what the resistance of a grounding electrode will be, and to what depth it must be driven to obtain low ground resistance. The resistivity of the soil varies widely throughout the world and changes seasonally. Soil resistivity is determined largely by its content of electrolytes, which consist of moisture, minerals and dissolved salts. A dry soil has high resistivity if it contains no soluble salts (Figure 1).

Soil	Resistivity (approx), Ω -cm		
	Min.	Average	Max.
Ashes, cinders, brine, waste	590	2,370	7,000
Clay, shale, gumbo, loam	340	4,060	16,300
Same, with varying proportions of sand and gravel	1,020	15,800	135,000
Gravel, sand, stones with little clay or loam	59,000	94,000	458,000

FIGURE 1

Factors Affecting Soil Resistivity

Two samples of soil, when thoroughly dried, may in fact become very good insulators having a resistivity in excess of 10^9 ohm-centimeters. The resistivity of the soil sample is seen to change quite rapidly until approximately 20% or greater moisture content is reached (Figure 2).

Moisture content % by weight	Resistivity Ω -cm	
	Top soil	Sandy loam
0	>10 ⁹	>10 ⁹
2.5	250,000	150,000
5	165,000	43,000
10	53,000	18,500
15	19,000	10,500
20	12,000	6,300
30	6,400	4,200

FIGURE 2

The resistivity of the soil is also influenced by temperature. Figure 3 shows the variation of the resistivity of sandy loam, containing 15.2% moisture, with temperature changes from 20° to -15°C. In this temperature range the resistivity is seen to vary from 7200 to 330,000 ohm-centimeters.

Temperature		Resistivity Ohm-cm
C	F	
20	68	7,200
10	50	9,900
0	32 (water)	13,800
0	32 (ice)	30,000
-5	23	79,000
-15	14	330,000

FIGURE 3

Because soil resistivity directly relates to moisture content and temperature, it is reasonable to assume that the resistance of any grounding system will vary throughout the different seasons of the year. Such variations are shown in Figure 4. Since both temperature and moisture content become more stable at greater distances below the surface of the earth, it follows that a grounding system, to be most effective at all times, should be constructed with the ground rod driven down a considerable distance below the surface of the earth. Best results are obtained if the ground rod reaches the water table.

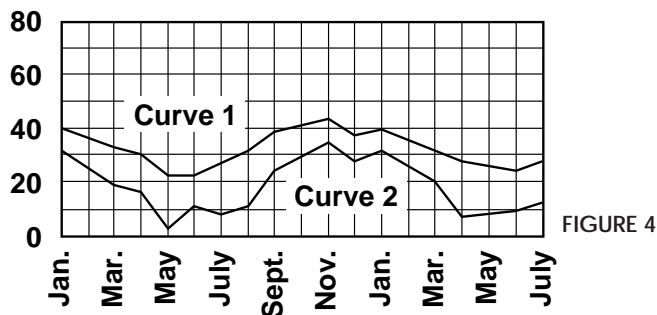

FIGURE 4

Seasonal variation of earth resistance with an electrode of 3/4 inch pipe in rather stony clay soil. Depth of electrode in earth is 3 ft for Curve 1, and 10 ft for Curve 2

NOTES

In some locations, the resistivity of the earth is so high that low-resistance grounding can be obtained only at considerable expense and with an elaborate grounding system.

In such situations, it may be economical to use a ground rod system of limited size and to reduce the ground resistivity by periodically increasing the soluble chemical content of the soil. Figure 5 shows the substantial reduction in resistivity of sandy loam brought about by an increase in chemical salt content.

THE EFFECT OF SALT* CONTENT ON THE RESISTIVITY OF SOIL	
(Sandy loam, Moisture content, 15% by weight, Temperature, 17°C)	
Added Salt (% by weight of moisture)	Resistivity (Ohm-centimeters)
0	10,700
0.1	1,800
1.0	460
5	190
10	130
20	100

FIGURE 5

Chemically treated soil is also subject to considerable variation of resistivity with temperature changes, as shown in Figure 6. If salt treatment is employed, it is necessary to use ground rods which will resist chemical corrosion.

THE EFFECT OF TEMPERATURE ON THE RESISTIVITY OF SOIL CONTAINING SALT*	
(Sandy loam, 20% moisture. Salt 5% of weight of moisture)	
Temperature (Degrees C)	Resistivity (Ohm-centimeters)
20	110
10	142
0	190
-5	312
-13	1,440

FIGURE 6

*Such as copper sulfate, sodium carbonate, and others. Salts must be EPA or local ordinance approved prior to use.

Soil Resistivity Measurements (4-Point Measurement)

Resistivity measurements are of two types; the 2-point and the 4-point method. The 2-point method is simply the resistance measured between two points. For most applications the most accurate method is the 4-point method which is used in the Model 4610 or Model 4500 Ground Tester. The 4-point method (Figures 7 and 8), as the name implies, requires the insertion of four equally spaced and in-line electrodes into the test area. A known current from a constant current generator is passed between the outer electrodes. The potential drop (a function of the resistance) is then measured across the two inner electrodes. The Model 4610 and Model 4500 are calibrated to read directly in ohms.

$$\rho = \frac{4\pi AR}{1 + \frac{2A}{\sqrt{(A^2 + 4B^2)}} - \frac{2A}{\sqrt{(4A^2 + 4B^2)}}$$

Where: A = distance between the electrodes in centimeters
 B = electrode depth in centimeters

If A > 20 B, the formula becomes:

- ρ = 2π AR (with A in cm)
- ρ = 191.5 AR (with A in feet)
- ρ = Soil resistivity (ohm-cm)

This value is the average resistivity of the ground at a depth equivalent to the distance "A" between two electrodes.

Soil Resistivity Measurements with the Model 4500

Given a sizable tract of land in which to determine the optimum soil resistivity some intuition is in order. Assuming that the objective is low resistivity, preference should be given to an area containing moist loam as opposed to a dry sandy area. Consideration must also be given to the depth at which resistivity is required.

Example

After inspection, the area investigated has been narrowed down to a plot of ground approximately 75 square feet (7 m²). Assume that you need to determine the resistivity at a depth of 15 feet (450 cm). The distance "A" between the electrodes must then be equivalent to the depth at which average resistivity is to be determined (15 ft, or 450 cm). Using the more simplified Wenner formula (ρ = 2π AR), the electrode depth must then be 1/20th of the electrode spacing or 8-7/8" (22.5 cm).

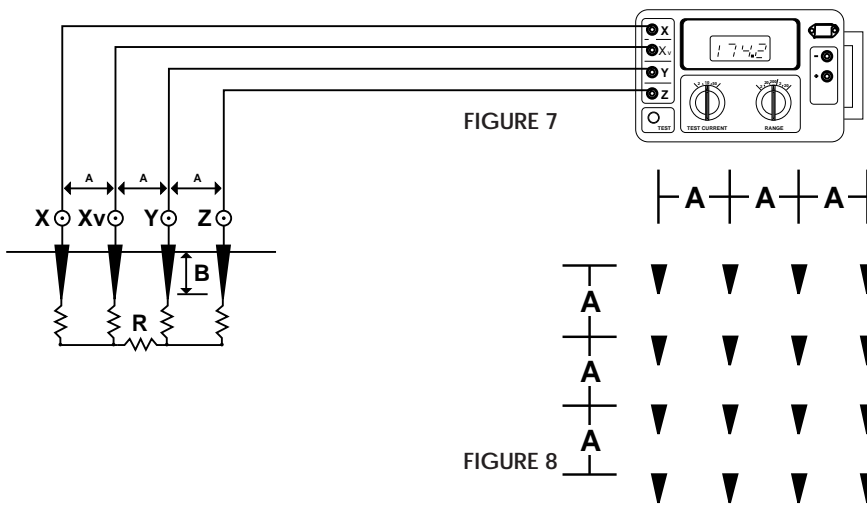

Lay out the electrodes in a grid pattern and connect to the Model 4500 as shown in Figure 8. Proceed as follows:

- Remove the shoring link between X and Xv (C1, P1)
- Connect all four auxiliary rods (Figure 7)

For example, if the reading is $R = 15$

$$\rho \text{ (resistivity)} = 2\pi \times A \times R$$

$$A \text{ (distance between electrodes)} = 450 \text{ cm}$$

$$\rho = 6.28 \times 15 \times 450 = 42,390 \text{ } \Omega\text{-cm}$$

Ground Electrodes

The term “ground” is defined as a conducting connection by which a circuit or equipment is connected to the earth. The connection is used to establish and maintain as closely as possible the potential of the earth on the circuit or equipment connected to it. A “ground” consists of a grounding conductor, a bonding connector, its grounding electrode(s), and the soil in contact with the electrode.

Grounds have several protection applications. For natural phenomena such as lightning, grounds are used to discharge the system of current before personnel can be injured or system components damaged. For foreign potentials due to faults in electric power systems with ground returns, grounds help ensure rapid operation of the protection relays by providing low resistance fault current paths. This provides for the removal of the foreign potential as quickly as possible. The ground should drain the foreign potential before personnel are injured and the power or communications system is damaged.

Ideally, to maintain a reference potential for instrument safety, protect against static electricity, and limit the system to frame voltage for operator safety, a ground resistance should be zero ohms. In reality, as we describe further in the text, this value cannot be obtained.

Last but not least, low ground resistance is essential to meet NEC®, OSHA and other electrical safety standards.

Figure 9 illustrates a grounding rod. The resistance of the electrode has the following components:

- (A) the resistance of the metal and that of the connection to it.
- (B) the contact resistance of the surrounding earth to the electrode.
- (C) the resistance in the surrounding earth to current flow or earth resistivity which is often the most significant factor.

More specifically:

- (A) Grounding electrodes are usually made of a very conductive metal (copper or copper clad) with adequate cross sections so that the overall resistance is negligible.

(B) The National Institute of Standards and Technology has demonstrated that the resistance between the electrode and the surrounding earth is negligible if the electrode is free of paint, grease, or other coating, and if the earth is firmly packed.

(C) The only component remaining is the resistance of the surrounding earth. The electrode can be thought of as being surrounded by concentric shells of earth or soil, all of the same thickness. The closer the shell to the electrode, the smaller its surface; hence, the greater its resistance. The farther away the shells are from the electrode, the greater the surface of the shell; hence, the lower the resistance. Eventually, adding shells at a distance

from the grounding electrode will no longer noticeably affect the overall earth resistance surrounding the electrode. The distance at which this effect occurs is referred to as the effective resistance area and is directly dependent on the depth of the grounding electrode.

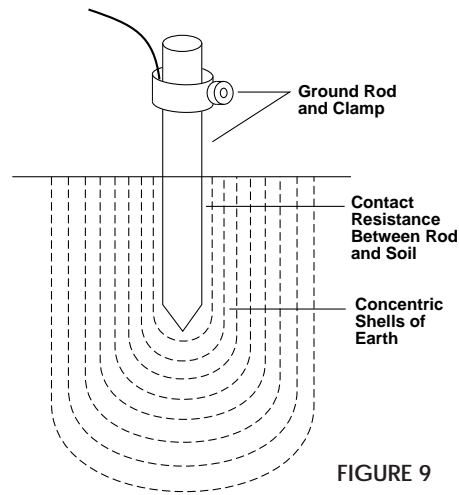

FIGURE 9

In theory, the ground resistance may be derived from the general formula:

$$R = \frac{\rho L}{A} \quad \text{Resistance} = \text{Resistivity} \times \frac{\text{Length}}{\text{Area}}$$

This formula illustrates why the shells of concentric earth decrease in resistance the farther they are from the ground rod:

$$R = \text{Resistivity of Soil} \times \frac{\text{Thickness of Shell}}{\text{Area}}$$

In the case of ground resistance, uniform earth (or soil) resistivity throughout the volume is assumed, although this is seldom the case in nature. The equations for systems of electrodes are very complex and often expressed only as approximations. The most commonly used formula for single ground electrode systems, developed by Professor H. R. Dwight of the Massachusetts Institute of Technology, is the following:

$$R = \frac{\rho}{2\pi L} \times \frac{\{(\ln 4L) - 1\}}{r}$$

R = resistance in ohms of the ground rod to the earth (or soil)

L = grounding electrode length

r = grounding electrode radius

ρ = average resistivity in ohms-cm.

Effect of Ground Electrode Size and Depth on Resistance

Size: Increasing the diameter of the rod does not materially reduce its resistance. Doubling the diameter reduces resistance by less than 10% (Figure 10).

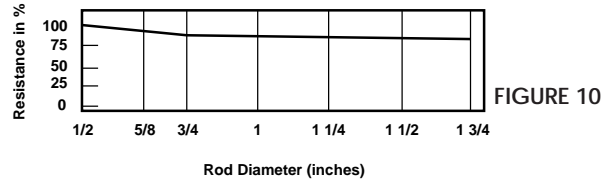

Depth: As a ground rod is driven deeper into the earth, its resistance is substantially reduced. In general, doubling the rod length reduces the resistance by an additional 40% (Figure 11). The NEC (1987, 250-83-3) requires a minimum of 8 ft (2.4 m) to be in contact with the soil. The most common is a 10 ft (3 m) cylindrical rod which meets the NEC code. A minimum diameter of 5/8 inch (1.59 cm) is required for steel rods and 1/2 inch (1.27 cm) for copper or copper clad steel rods (NEC 1987, 250-83-2). Minimum practical diameters for driving limitations for 10 ft (3 m) rods are:

- 1/2 inch (1.27 cm) in average soil
- 5/8 inch (1.59 cm) in moist soil
- 3/4 inch (1.91 cm) in hard soil or more than 10 ft driving depths

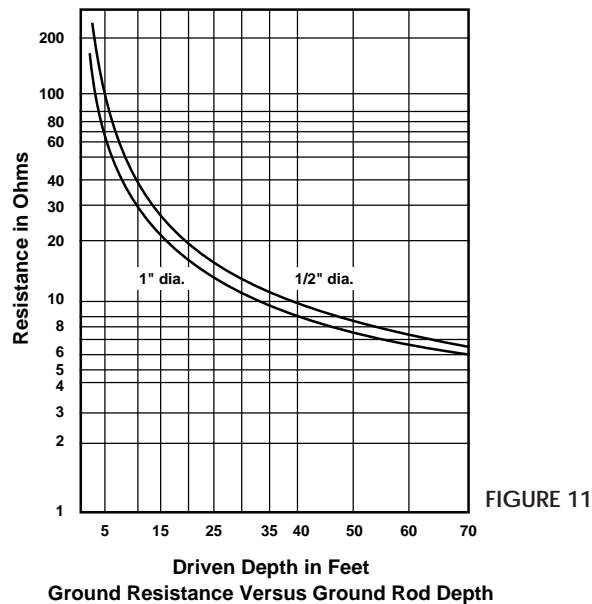

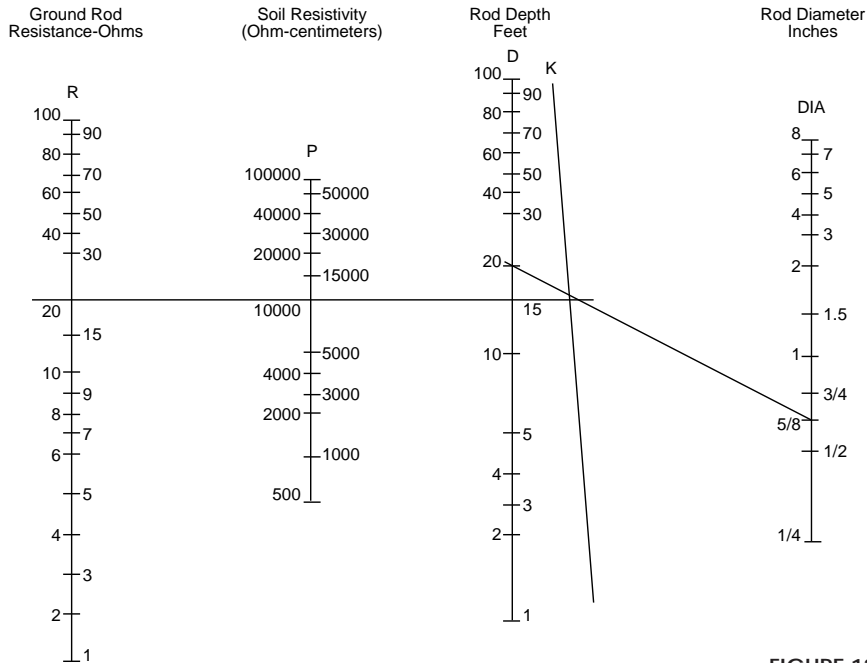

FIGURE 12

Grounding Nomograph

1. Select required resistance on R scale.
2. Select apparent resistivity on P scale.
3. Lay straightedge on R and P scale, and allow to intersect with K scale.
4. Mark K scale point.
5. Lay straightedge on K scale point & DIA scale, and allow to intersect with D scale.
6. Point on D scale will be rod depth required for resistance on R scale.

NOTES

Ground Resistance Values

NEC® 250-84 (1987): Resistance of man-made electrodes:

“A single electrode consisting of a rod, pipe, or plate which does not have a resistance to ground of 25 ohms or less shall be augmented by one additional rod of any of the types specified in section 250-81 or 250-83. Where multiple rod, pipe or plate electrodes are installed to meet the requirements of this section, they shall be not less than 6 ft (1.83 m) apart.”

The National Electrical Code® (NEC) states that the resistance to ground shall not exceed 25 ohms. This is an upper limit and guideline, since much lower resistance is required in many instances.

“How low in resistance should a ground be?” An arbitrary answer to this in ohms is difficult. The lower the ground resistance, the safer; and for positive protection of personnel and equipment, it is worth the effort to aim for less than one ohm. It is generally impractical to reach such a low resistance along a distribution system or a transmission line or in small substations. In some regions, resistances of 5 ohms or less may be obtained without much trouble.

NOTES

In other regions, it may be difficult to bring resistance of driven grounds below 100 ohms.

Accepted industry standards stipulate that transmission substations should be designed not to exceed 1Ω . In distribution substations, the maximum recommended resistance is for 5 ohms or even 1 ohm. In most cases, the buried grid system of any substation will provide the desired resistance.

In light industrial or in telecommunication central offices, 5Ω is often the accepted value. For lightning protection, the arrestors should be coupled with a maximum ground resistance of 1Ω .

These parameters can usually be met with the proper application of basic grounding theory. There will always exist circumstances which will make it difficult to obtain the ground resistance required by the NEC[®] or other safety standards. When these situations develop, several methods of lowering the ground resistance can be employed. These include parallel rod systems, deep driven rod systems utilizing sectional rods, and chemical treatment of the soil. Additional methods discussed in other published data are buried plates, buried conductors (counterpoise), electrically connected building steel, and electrically connected concrete reinforced steel.

Electrically connecting to existing water and gas distribution systems was often considered to yield low ground resistance; however, recent design changes utilizing non-metallic pipes and insulating joints have made this method of obtaining a low resistance ground questionable and in many instances unreliable.

The measurement of ground resistances may only be accomplished with specially designed test equipment. Most instruments use the fall-of-potential principle of alternating current (AC) circulating between an auxiliary electrode and the ground electrode under test. The reading will be given in ohms, and represents the resistance of the ground electrode to the surrounding earth. AEMC has also recently introduced clamp-on ground resistance testers.

Note: The National Electrical Code[®] and NEC[®] are registered trademarks of the National Fire Protection Association.

Ground Resistance Testing Principle (Fall of Potential – 3-Point Measurement)

The potential difference between rods X and Y is measured by a voltmeter, and the current flow between rods X and Z is measured by an ammeter. (Note: X, Y and Z may be referred to as X, P and C in a 3-point tester or C1, P2 and C2 in a 4-point tester.) (See Figure 13.)

By Ohm's Law $E = RI$ or $R = E/I$, we may obtain the ground electrode resistance R. If $E = 20$ V and $I = 1$ A, then

$$R = \frac{E}{I} = \frac{20}{1} = 20$$

It is not necessary to carry out all the measurements when using a ground tester. The ground tester will measure directly by generating its own current and displaying the resistance of the ground electrode.

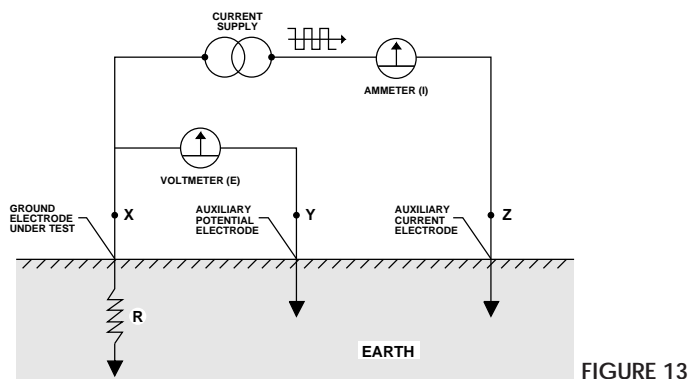

FIGURE 13

Position of the Auxiliary Electrodes on Measurements

The goal in precisely measuring the resistance to ground is to place the auxiliary current electrode Z far enough from the ground electrode under test so that the auxiliary potential electrode Y will be outside of the effective resistance areas of both the ground electrode and the auxiliary current electrode. The best way to find out if the auxiliary potential rod Y is outside the effective resistance areas is to move it between X and Z and to take a reading at each location. If the auxiliary potential rod Y is in an effective resistance area (or in both if they overlap, as in Figure 14), by displacing it the readings taken will vary noticeably in value. Under these conditions, no exact value for the resistance to ground may be determined.

On the other hand, if the auxiliary potential rod Y is located outside of the effective resistance areas (Figure 15), as Y is moved back and forth the reading variation is minimal. The readings taken should be relatively close to

NOTES

each other, and are the best values for the resistance to ground of the ground X. The readings should be plotted to ensure that they lie in a “plateau” region as shown in Figure 15. The region is often referred to as the “62% area.” (See page 13 for explanation).

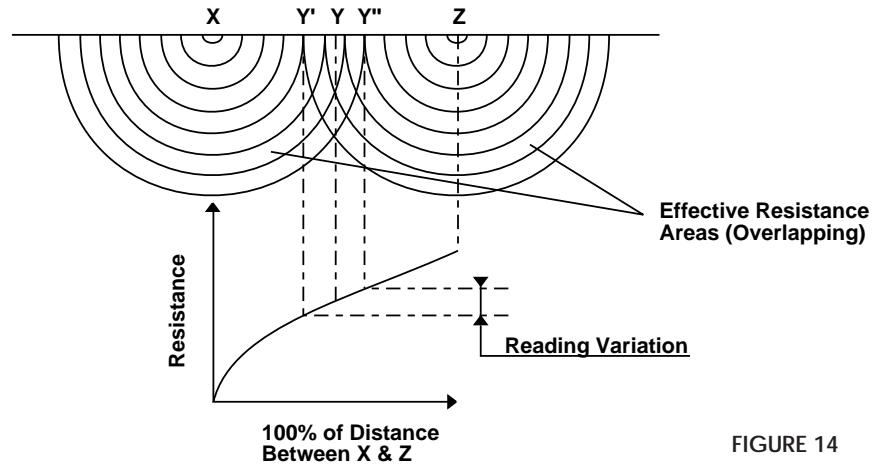

FIGURE 14

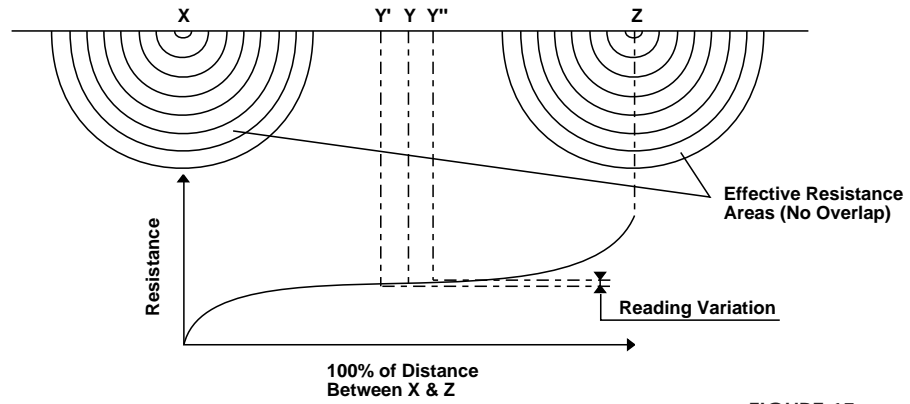
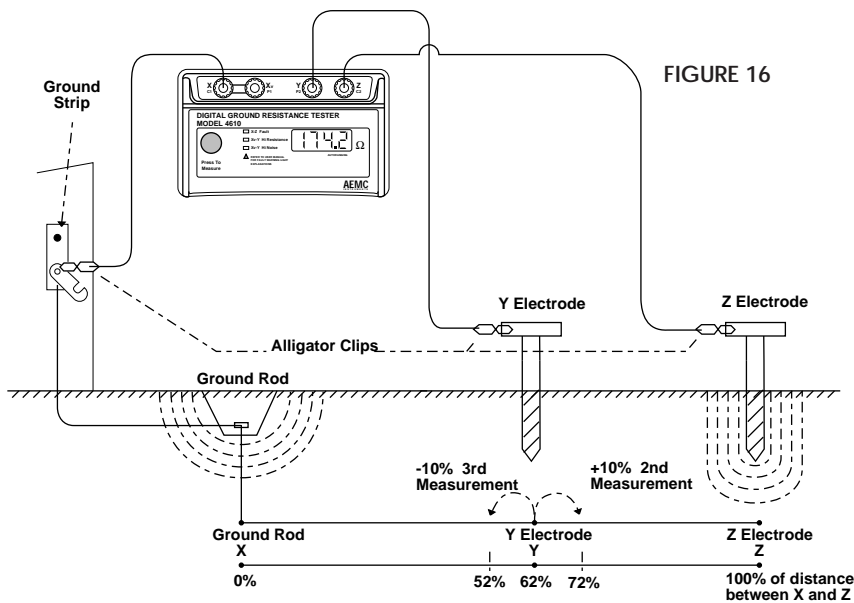

FIGURE 15

Measuring Resistance of Ground Electrodes (62% Method)

The 62% method has been adopted after graphical consideration and after actual test. It is the most accurate method but is limited by the fact that *the ground tested is a single unit*.

This method applies only when all three electrodes are in a straight line and the ground is a *single* electrode, pipe, or plate, etc., as in Figure 16.



Consider Figure 17, which shows the effective resistance areas (concentric shells) of the ground electrode X and of the auxiliary current electrode Z. The resistance areas overlap. If readings were taken by moving the auxiliary potential electrode Y towards either X or Z, the reading differentials would be great and one could not obtain a reading within a reasonable band of tolerance. The sensitive areas overlap and act constantly to increase resistance as Y is moved away from X.

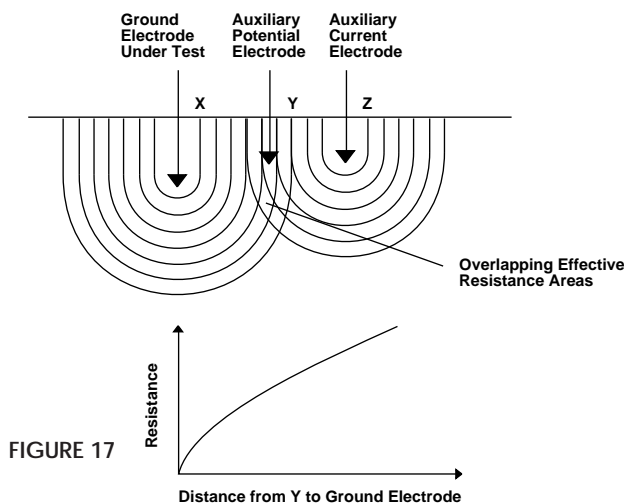

NOTES

Now consider Figure 18, where the X and Z electrodes are sufficiently spaced so that the areas of effective resistance do not overlap. If we plot the resistance measured we find that the measurements level off when Y is placed at 62% of the distance from X to Z, and that the readings on either side of the initial Y setting are most likely to be within the established tolerance band. This tolerance band is defined by the user and expressed as a percent of the initial reading: $\pm 2\%$, $\pm 5\%$, $\pm 10\%$, etc.

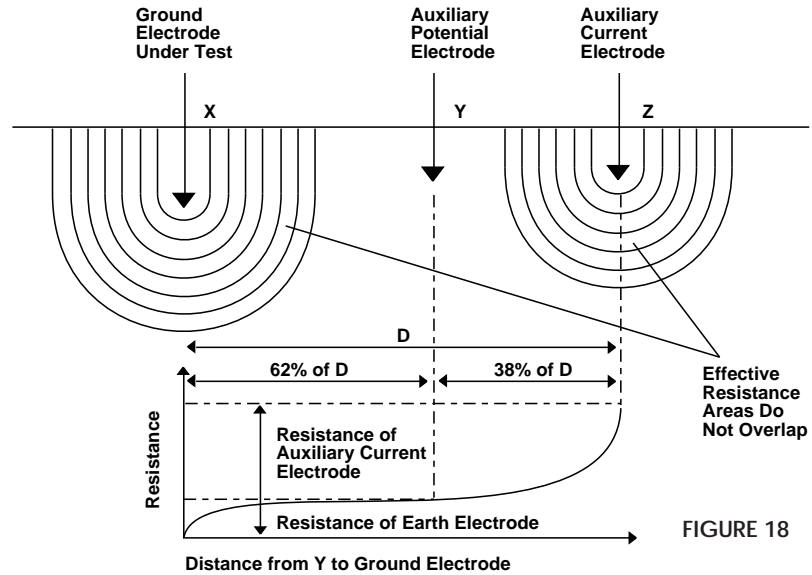

FIGURE 18

Auxiliary Electrode Spacing

No definite distance between X and Z can be given, since this distance is relative to the diameter of the electrode tested, its length, the homogeneity of the soil tested, and particularly, the effective resistance areas. However, an approximate distance may be determined from the following chart which is given for a homogeneous soil and an electrode of 1" in diameter. (For a diameter of 1/2", reduce the distance by 10%; for a diameter of 2" increase the distance by 10%.)

Approximate distance to auxiliary electrodes using the 62% method		
Depth Driven	Distance to Y	Distance to Z
6 ft	45 ft	72 ft
8 ft	50 ft	80 ft
10 ft	55 ft	88 ft
12 ft	60 ft	96 ft
18 ft	71 ft	115 ft
20 ft	74 ft	120 ft
30 ft	86 ft	140 ft

Multiple Electrode System

A single driven ground electrode is an economical and simple means of making a good ground system. But sometimes a single rod will not provide sufficient low resistance, and several ground electrodes will be driven and connected in parallel by a cable. Very often when two, three or four ground electrodes are being used, they are driven in a straight line; when four or more are being used, a hollow square configuration is used and the ground electrodes are still connected in parallel and are equally spaced (Figure 19).

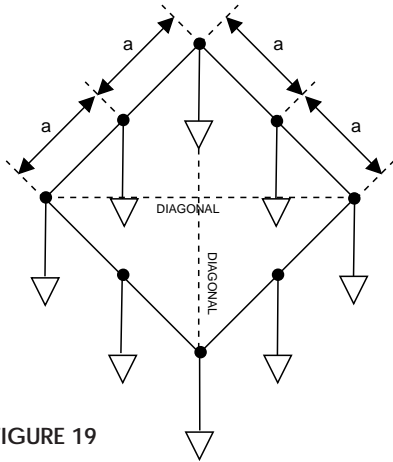

FIGURE 19

in a line, the total length. For example, a square having a side of 20 ft will have a diagonal of approximately 28 ft).

In multiple electrode systems, the 62% method electrode spacing may no longer be applied directly. The distance of the auxiliary electrodes is now based on the maximum grid distance (i.e. in a square, the diagonal;

Multiple Electrode System		
Max Grid Distance	Distance to Y	Distance to Z
6 ft	78 ft	125 ft
8 ft	87 ft	140 ft
10 ft	100 ft	160 ft
12 ft	105 ft	170 ft
14 ft	118 ft	190 ft
16 ft	124 ft	200 ft
18 ft	130 ft	210 ft
20 ft	136 ft	220 ft
30 ft	161 ft	260 ft
40 ft	186 ft	300 ft
50 ft	211 ft	340 ft
60 ft	230 ft	370 ft
80 ft	273 ft	440 ft
100 ft	310 ft	500 ft
120 ft	341 ft	550 ft
140 ft	372 ft	600 ft
160 ft	390 ft	630 ft
180 ft	434 ft	700 ft
200 ft	453 ft	730 ft

Two-Point Measurement (Simplified Method)

This is an alternative method *when an excellent ground is already available*.

In congested areas where finding room to drive the two auxiliary rods may be a problem, the two-point measurement method may be applied. The reading obtained will be that of the two grounds in series. Therefore, the water pipe or other ground must be very low in resistance so that it will be negligible in the final measurement. The lead resistances will also be measured and should be deducted from the final measurement.

This method is not as accurate as three-point methods (62% method), as it is particularly affected by the distance between the tested electrode and the dead ground or water pipe. This method should not be used as a standard procedure, but rather as a back-up in tight areas. See Figure 20.

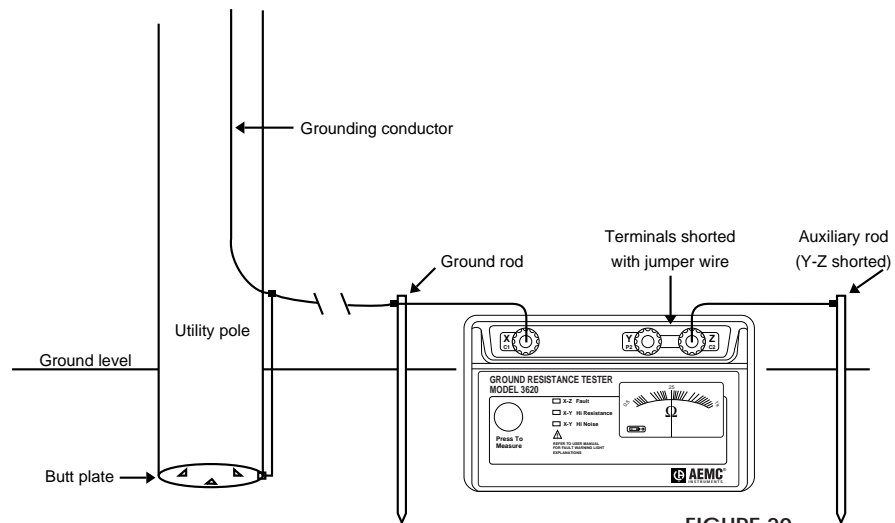

FIGURE 20

Continuity Measurement

Continuity measurements of a ground conductor are possible by using two terminals (Figure 21).

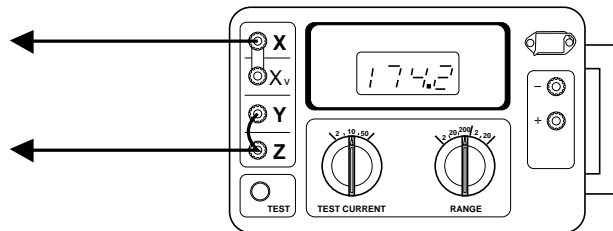

FIGURE 21

Tech Tips

Excessive Noise

Excessive noise may interfere with testing because of the long leads used to perform a fall-of-potential test. A voltmeter can be utilized to identify this problem. Connect the "X", "Y" and "Z" cables to the auxiliary electrodes as for a standard ground resistance test. Use the voltmeter to test the voltage across terminals "X" and "Z" (Figure 22).

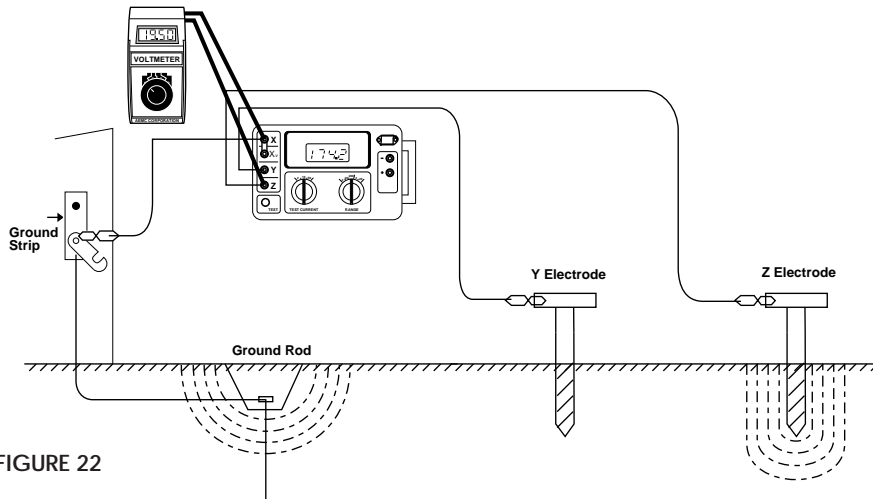

FIGURE 22

The voltage reading should be within stray voltage tolerances acceptable to your ground tester. If the voltage exceeds this value, try the following techniques:

A) Braid the auxiliary cables together. This often has the effect of canceling out the common mode voltages between these two conductors (Figure 23).

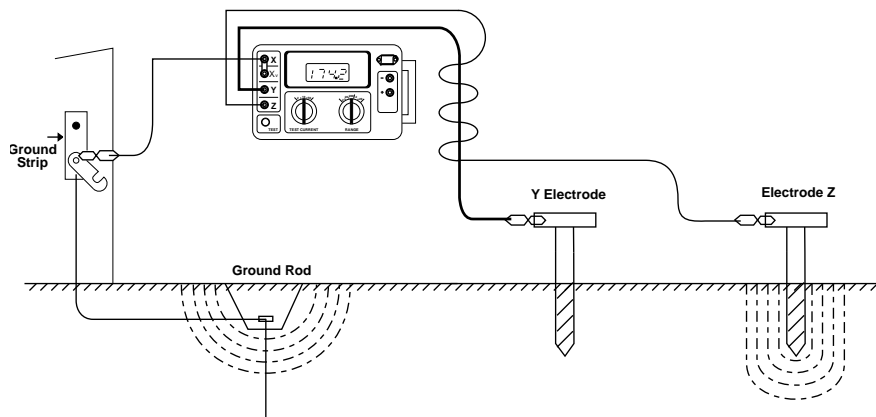

FIGURE 23

NOTES

B) If the previous method fails, try changing the alignment of the auxiliary cables so that they are not parallel to power lines above or below the ground (Figure 24).

C) If a satisfactory low voltage value is still not obtained, the use of shielded cables may be required. The shield acts to protect the inner conductor by capturing the voltage and draining it to ground (Figure 25).

1. Float the shields at the auxiliary electrodes.
2. Connect all three shields together at (but not to) the instrument.
3. Solidly ground the remaining shield to the ground under test.

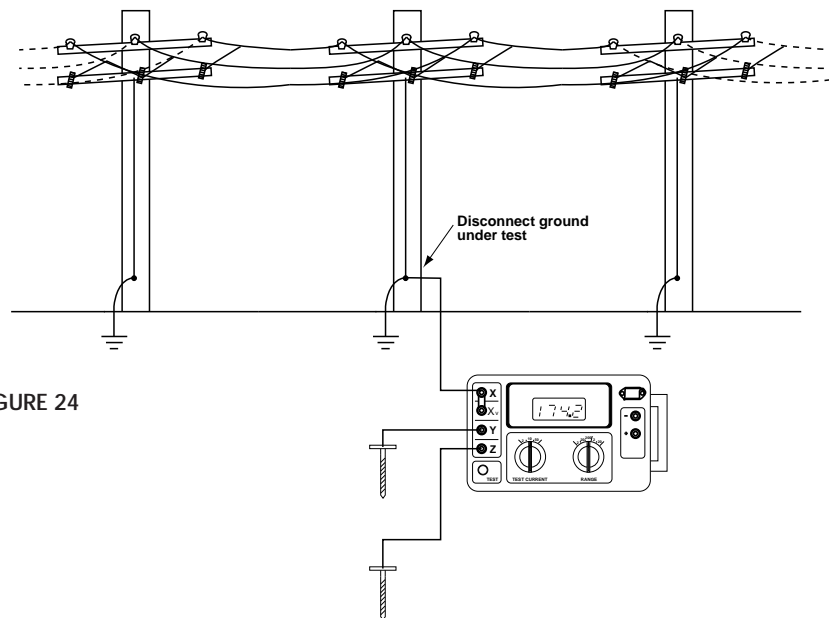

FIGURE 24

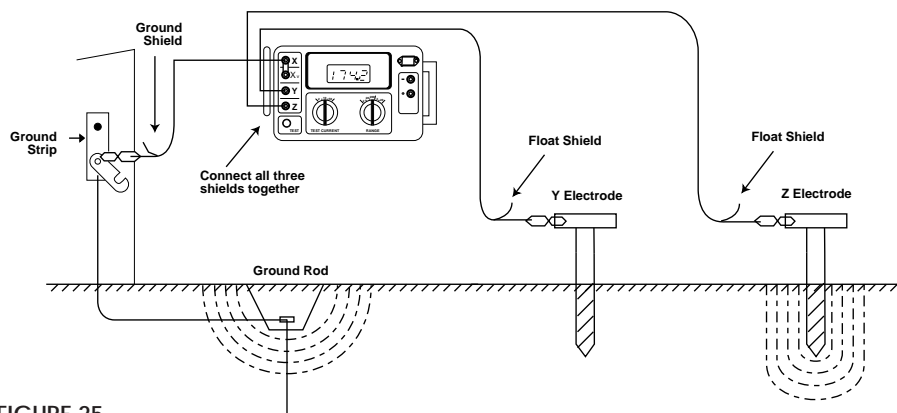

FIGURE 25

Excessive Auxiliary Rod Resistance

The inherent function of a fall-of-potential ground tester is to input a constant current into the earth and measure the voltage drop by means of auxiliary electrodes. Excessive resistance of one or both auxiliary electrodes can inhibit this function. This is caused by high soil resistivity or poor contact between the auxiliary electrode and the surrounding dirt (Figure 26).

To ensure good contact with the earth, stamp down the soil directly around the auxiliary electrode to remove air gaps formed when inserting the rod. If soil resistivity is the problem, pour water around the auxiliary electrodes. This reduces the auxiliary electrode's contact resistance without affecting the measurement.

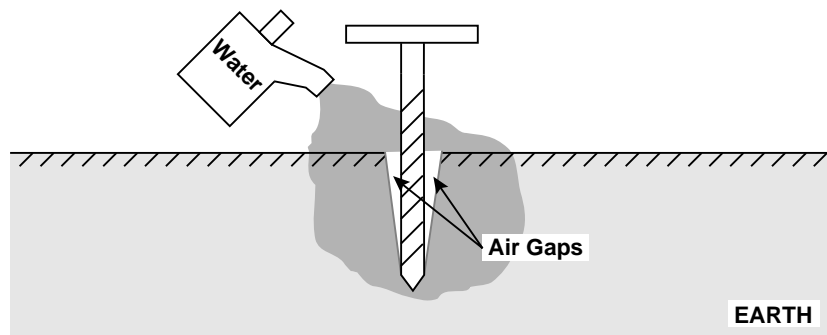

FIGURE 26

Tar or Concrete Mat

Sometimes a test must be performed on a ground rod that is surrounded by a tar or concrete mat, where auxiliary electrodes cannot be driven easily. In such cases, metal screens and water can be used to replace auxiliary electrodes, as shown in Figure 27.

Place the screens on the floor the same distance from the ground rod under test as you would auxiliary electrodes in a standard fall-of-potential test. Pour water on the screens and allow it to soak in. These screens will now perform the same function as would driven auxiliary electrodes.

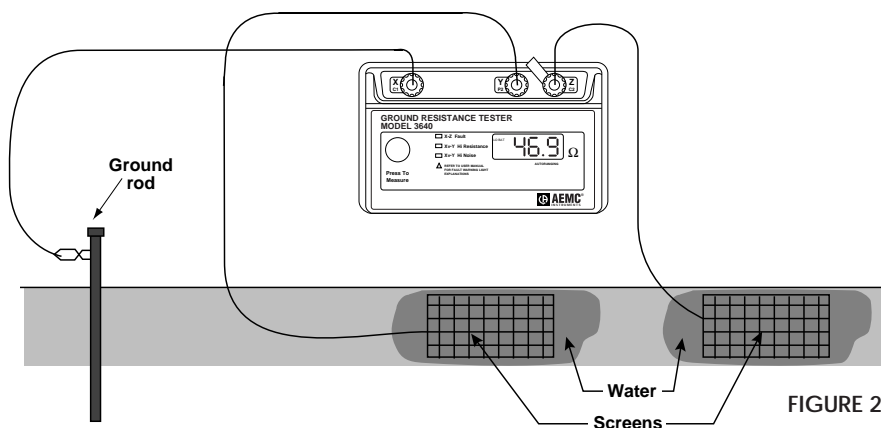

FIGURE 27

Touch Potential Measurements

The primary reason for performing fall-of-potential measurements is to observe electrical safety of personnel and equipment. However, in certain circumstances the degree of electrical safety can be evaluated from a different perspective.

Periodic ground electrode or grid resistance measurements are recommended when:

- 1) The electrode/grid is relatively small and is able to be conveniently disconnected.
- 2) Corrosion induced by low soil resistivity or galvanic action is suspected.
- 3) Ground faults are very unlikely to occur near the ground under test.

Touch potential measurements are an alternative method for determining electrical safety. Touch potential measurements are recommended when:

- 1) It is physically or economically impossible to disconnect the ground to be tested.
- 2) Ground faults could reasonably be expected to occur near the ground to be tested, or near equipment grounded by the ground to be tested.
- 3) The “footprint” of grounded equipment is comparable to the size of the ground to be tested. (The “footprint” is the outline of the part of equipment in contact with the earth.)

Neither fall-of-potential resistance measurements nor touch potential measurements tests the ability of grounding conductors to carry high phase-to-ground fault currents. Additional high current tests should be performed to verify that the grounding system can carry these currents.

When performing touch potential measurements, a four-pole ground resistance tester is used. During the test, the instrument induces a low level fault into the earth at some proximity to the subject ground. The instrument displays touch-potential in volts per ampere of fault current. The displayed value is then multiplied by the largest anticipated ground fault current to obtain the worst case touch potential for a given installation.

For example, if the instrument displayed a value of $.100\Omega$ when connected to a system where the maximum fault current was expected to be 5000 A, the maximum touch potential would be: $5000 \times .1 = 500$ volts.

Touch potential measurements are similar to fall-of-potential measurements in that both measurements require placement of auxiliary electrodes into or on top of the earth. Spacing the auxiliary electrodes during touch potential measurements differs from fall-of-potential electrode spacing, as shown in Figure 28 on the following page.

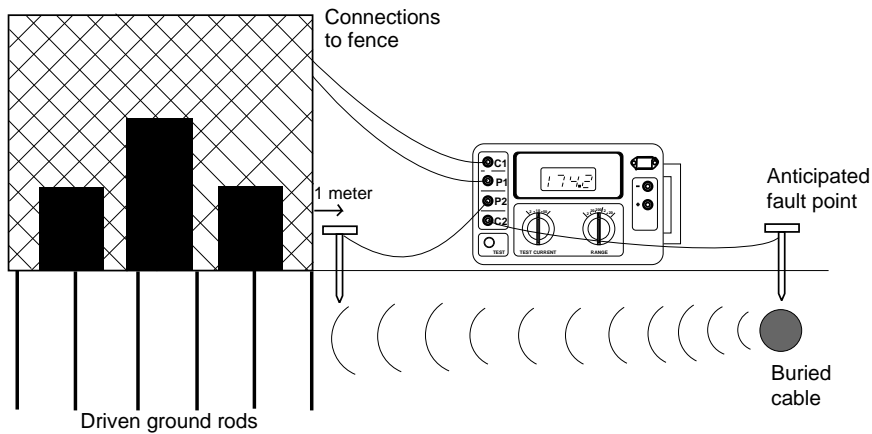

FIGURE 28

Consider the following scenario: If the buried cable depicted in Figure 28 experienced an insulation breakdown near the substation shown, fault currents would travel through the earth towards the substation ground, creating a voltage gradient. This voltage gradient may be hazardous or potentially lethal to personnel who come in contact with the affected ground.

To test for approximate touch potential values in this situation, proceed as follows: Connect cables between the fence of the substation and C1 and P1 of the four-pole earth resistance tester. Position an electrode in the earth at the point at which the ground fault is anticipated to occur, and connect it to C2. In a straight line between the substation fence and the anticipated fault point, position an auxiliary electrode into the earth one meter (or one arm's length) away from the substation fence, and connect it to P2. Turn the instrument on, select the 10 mA current range, and observe the measurement. Multiply the displayed reading by the maximum fault current of the anticipated fault.

By positioning the P2 electrode at various positions around the fence adjacent to the anticipated fault line, a voltage gradient map may be obtained.

Clamp-on Ground Resistance Measurement (Models 3710 and 3730)

This measurement method is innovative and quite unique. It offers the ability to measure the resistance without disconnecting the ground. This type of measurement also offers the advantage of including the bonding to ground and the overall grounding connection resistances.

Principle of Operation

Usually, a common distribution line grounded system can be simulated as a simple basic circuit as shown in Figure 29 or an equivalent circuit, shown in Figure 30. If voltage E is applied to any measured grounding pole R_x through a special transformer, current I flows through the circuit, thereby establishing the following equation.

$$E/I = R_x + \frac{1}{\sum_{k=1}^n \frac{1}{R_k}} \quad \text{where, usually} \quad R_x \gg \frac{1}{\sum_{k=1}^n \frac{1}{R_k}}$$

Therefore, $E/I = R_x$ is established. If I is detected with E kept constant, measured grounding pole resistance can be obtained. Refer again to Figures 29 and 30. Current is fed to a special transformer via a power amplifier from a 1.7 kHz constant voltage oscillator. This current is detected by a detection CT. Only the 1.7 kHz signal frequency is amplified by a filter amplifier. This occurs before the A/D conversion and after synchronous rectification. It is then displayed on the LCD.

The filter amplifier is used to cut off both earth current at commercial frequency and high-frequency noise. Voltage is detected by coils wound around the injection CT which is then amplified, rectified, and compared by a level comparator. If the clamp is not closed properly, an "open jaw" annunciator appears on the LCD.

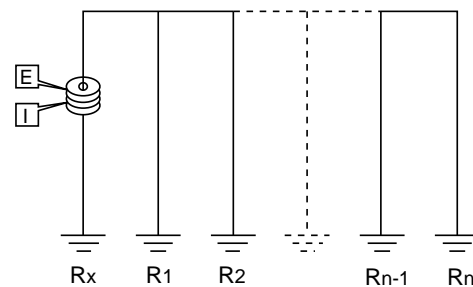

FIGURE 29

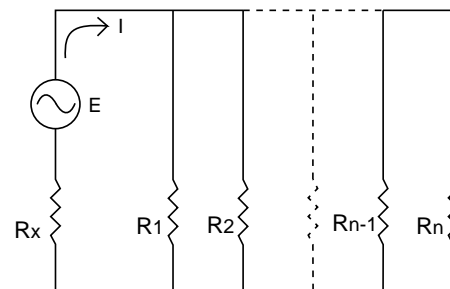

FIGURE 30

Examples: Typical In-Field Measurements

Pole Mounted Transformer

Remove any molding covering the ground conductor, and provide sufficient room for the Model 3710/3730 jaws, which must be able to close easily around the conductor. The jaws can be placed around the ground rod itself. **Note:** The clamp must be placed so that the jaws are in an electrical path from the system neutral or ground wire to the ground rod or rods as the circuit provides.

Select the current range "A." Clamp onto the ground conductor and measure the ground current. The maximum current range is 30 A. If the ground current exceeds 5 A, ground resistance measurements are not possible. *Do not proceed further with the measurement.* Instead, remove the clamp-on tester from the circuit, noting the location for maintenance, and continue to the next test location.

After noting the ground current, select the ground resistance range " Ω " and measure the resistance directly. The reading you measure with the 3710/3730 indicates the resistance not just of the rod, but also of the connection to the system neutral and all bonding connections between the neutral and the rod.

Note that in Figure 31 there is both a butt plate and a ground rod. In this type of circuit, the instrument must be placed above the bond so that both grounds are included in the test. For future reference note the date, ohms reading, current reading and pole number. Replace any molding you may have removed from the conductor. **Note:** A high reading indicates one or more of the following:

- A) poor ground rod
- B) open ground conductor
- C) high resistance bonds on the rod or splices on the conductor; watch for buried split butts, clamps, and hammer-on connections.

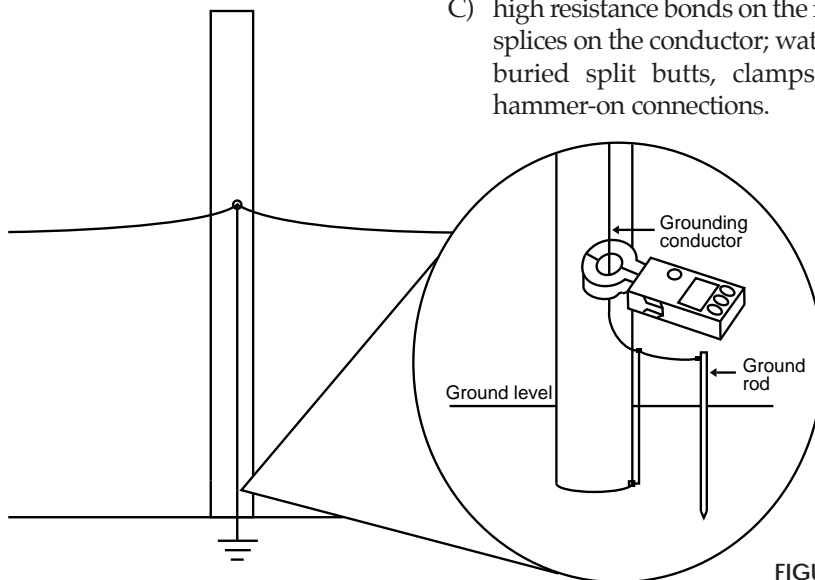
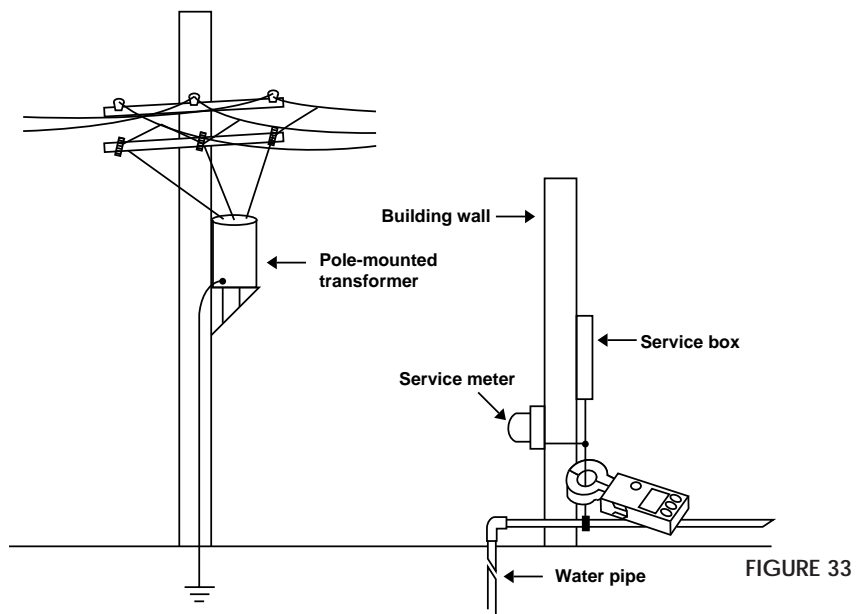
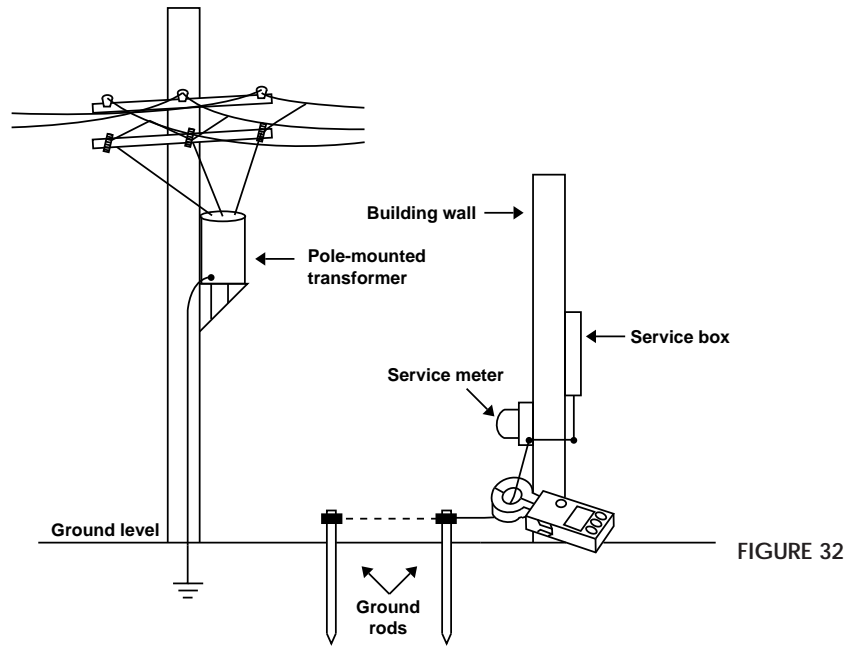

FIGURE 31

NOTES

Service Entrance or Meter

Follow basically the same procedure as in the first example. Notice that Figure 32 shows the possibility of multiple ground rods, and in Figure 33 the ground rods have been replaced with a water pipe ground. You may also have both types acting as a ground. In these cases, it is necessary to make the measurements between the service neutral and both grounded points.



Pad Mounted Transformer

Note: Never open transformer enclosures. They are the property of the electrical utility. This test is for high voltage experts only.

Observe all safety requirements, since dangerously high voltage is present. Locate and number all rods (usually only a single rod is present). If the ground rods are inside the enclosure, refer to Figure 34 and if they are outside the enclosure, refer to Figure 35. If a single rod is found within the enclosure, the measurement should be taken on the conductor just before the bond on the ground rod. Often, more than one ground conductor is tied to this clamp, looping back to the enclosure or neutral.

In many cases, the best reading can be obtained by clamping the 3710/3730 onto the ground rod itself, below the point when the ground conductors are attached to the rod, so that you are measuring the ground circuit. Care must be taken to find a conductor with only one return path to the neutral.

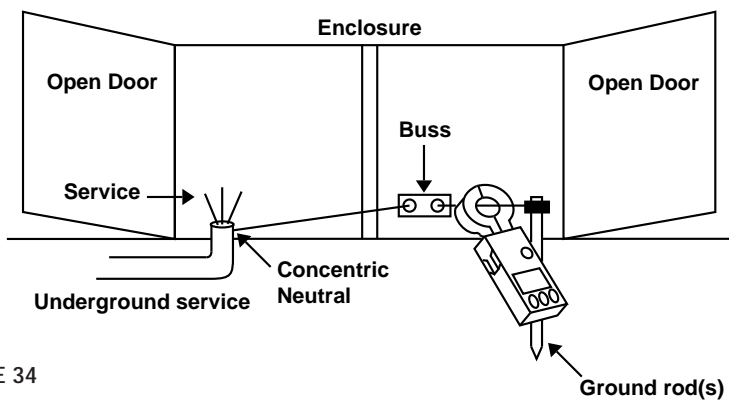

FIGURE 34

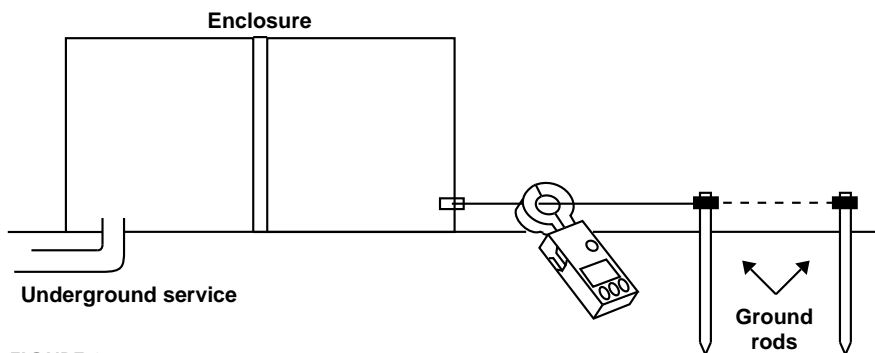

FIGURE 35

Transmission Towers

Observe all safety requirements, since dangerously high voltage is present. Locate the ground conductor at the base of the tower. **Note:** Many different configurations exist. Care should be taken when searching for the ground conductor. Fig. 36 shows a single leg mounted on a concrete pad with an external ground conductor. The point at which you clamp the ground tester should be above all splices and connections which allow for multiple rods, butt wraps, or butt plates.

Central Office Locations

The main ground conductor from ground window or ground plane is often too large to clamp around. Due to the wiring practices within the central office, there are many locations at which you can look at the water pipe or counterpoise from within the building. An effective location is usually at the ground buss in the power room, or near the backup generator.

By measuring at several points and comparing the readings, both of current flow and resistance, you will be able to identify neutral loops, utility grounds and central office grounds. The test is effective and accurate because the ground window is connected to the utility ground at only one point, according to standard practices.

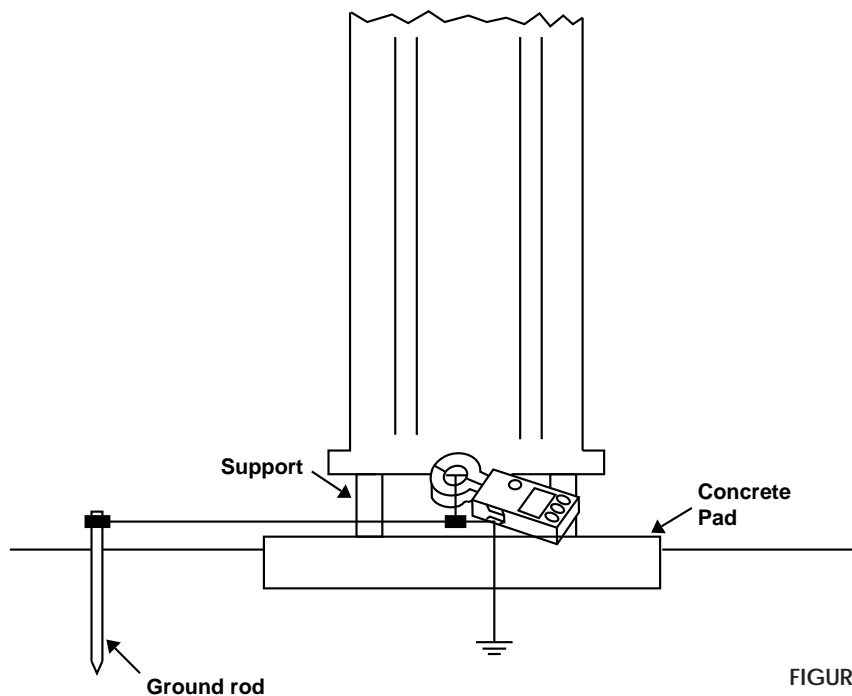

FIGURE 36

Telecommunications

The clamp-on ground tester developed by AEMC and discussed in the previous chapter has revolutionized the ability of power companies to measure their ground resistance values. This same proven instrument and technology can be applied to telephone industries to aid in detecting grounding and bonding problems. As equipment operates at lower voltages, the system's ability to remove any manmade or natural overpotentials becomes even more critical. The traditional fall-of-potential tester proved to be labor intensive and left a lot of interpretation to the person making the test. Even more important, the clamp-on ground test method allows the user to make this necessary reading without the risky business of removing the ground under test from service.

In many applications, the ground consists of bonding the two Utilities together to avoid any difference of potentials that could be dangerous to equipment and personnel alike. The clamp-on "Ohm meter" can be used to test these important bonds.

Here are some of the solutions and clamp-on procedures that have applications to the telephone industry.

Telephone Cabinets and Enclosures

Grounding plays a very important role in the maintenance of sensitive equipment in telephone cabinets and enclosures. In order to protect this equipment, a low resistance path must be maintained in order for any over-voltage potentials to conduct safely to earth. This resistance test is performed by clamping a ground tester Model 3710/3730 around the driven ground rod, below any common telephone and power company bond connections.

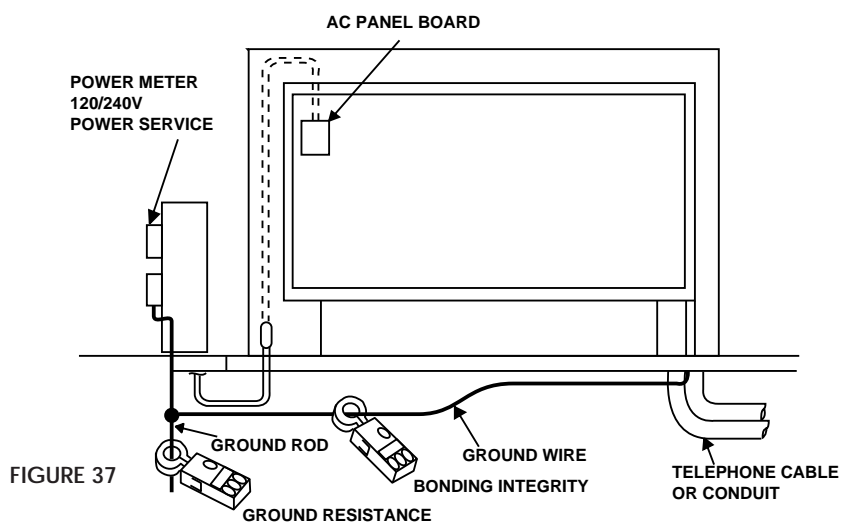

NOTES

To avoid any high voltage potentials between the telephone and power companies, a low resistance bond is established. Bonding integrity is performed by clamping around the No. 6 copper wire between the master ground bar (MGB) and the power company's multigrounded neutral (MGN). The resistance value displayed on the tester will also include loose or poorly landed terminations that may have degraded over time.

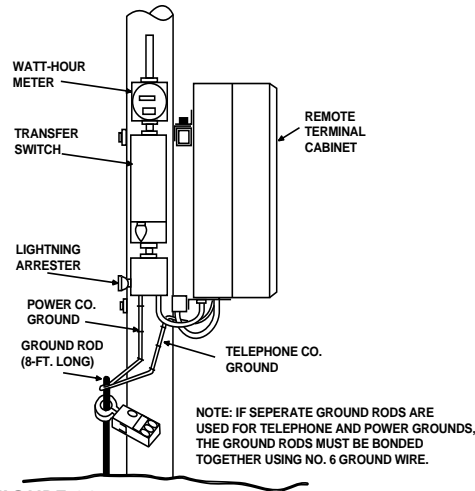

FIGURE 38

Additionally, the clamp-on ground tester can be used as a True RMS ammeter.

Pedestal grounds

All cable sheaths are bonded to a ground bar inside each pedestal. This ground bar is connected to earth by means of a driven ground rod. The ground rod resistance can be found by using the instrument clamped around the ground rod or the No. 6 cable connecting these two points. See figure 39.

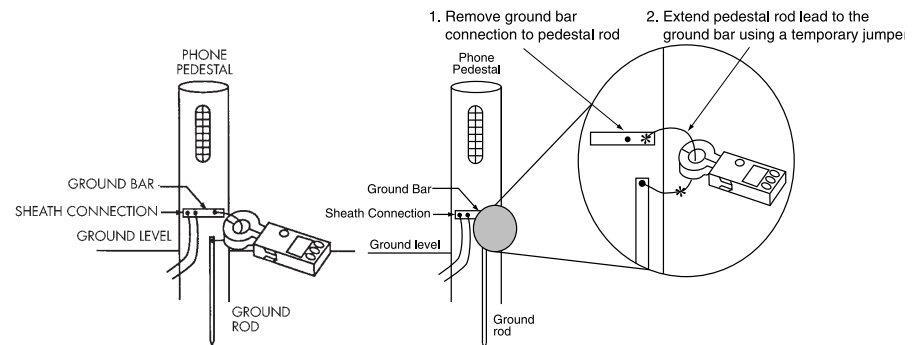

FIGURE 39

Note: temporary jumper required only if pedestal does not allow tester to fit.

Cable shield bonds to MGN

The cable shields in a buried or above ground telephone enclosure may be grounded by means of the power company's multigrounded neutral. The clamp-on ground tester can be utilized to ensure that this connection has been successfully terminated. The low resistance return path for the instru-

ment to make this measurement will be from this bond wire under test to the MGN back through all other bonds up and/or down stream (theory of parallel resistance).

The clamp-on ground tester also is a True RMS ammeter.

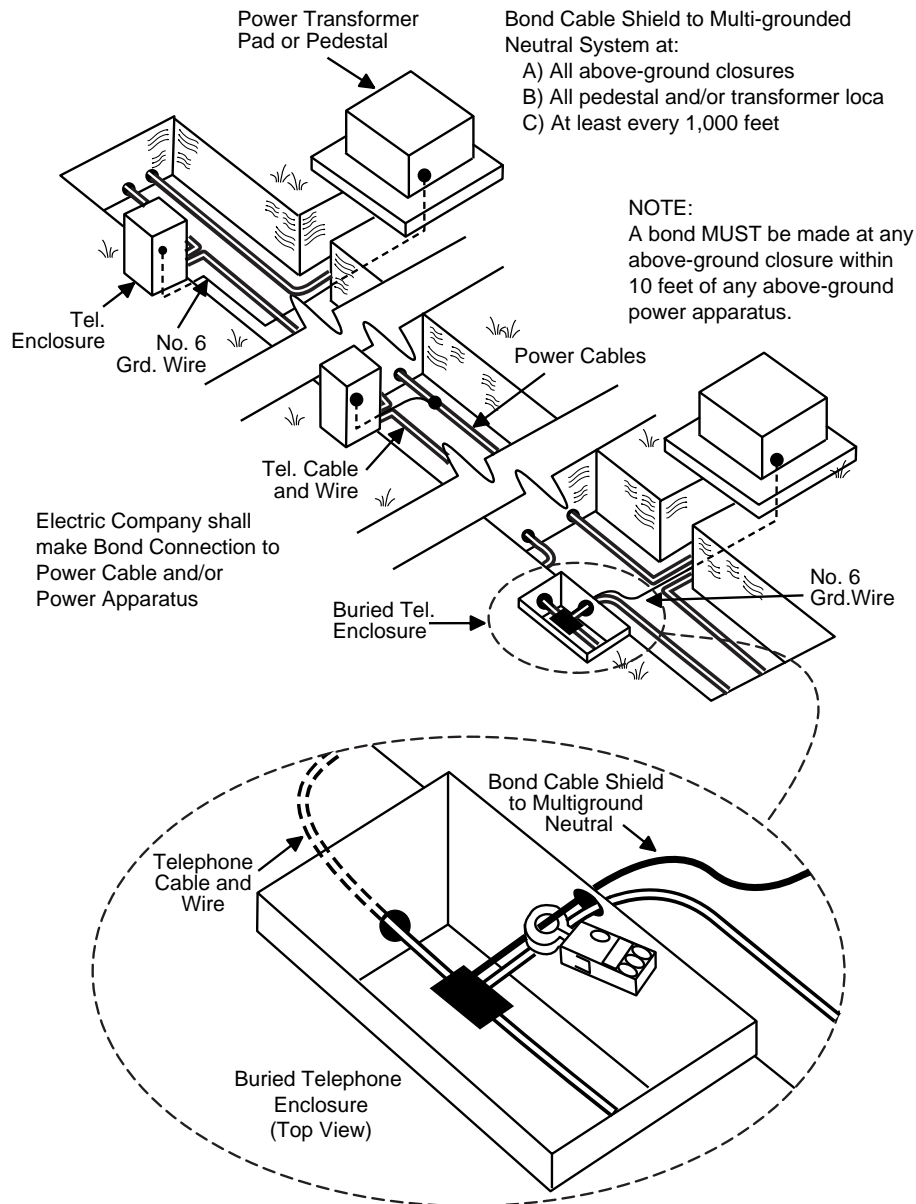

JOINT BURIED CONSTRUCTION – RANDOM SEPARATION

FIGURE 40

Network Interface Device (NID) with a Protector Block

The typical customer connection is achieved with the tip and ring drop cable pair.

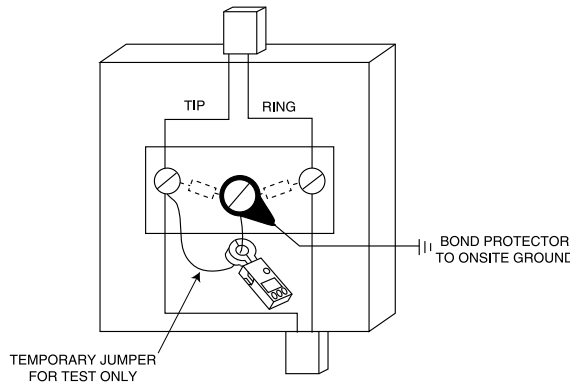

FIGURE 41

In order to protect against an overvoltage situation on the telephone wires, a protector block is installed inside the NID. This protector has two internal devices that conduct only when unwanted overvoltages are present. In order for the protector to function properly, it must have a low resistance path for any fault to conduct to earth. This bonding and ground resistance potential can be verified by using the clamp-on ground resistance tester. Simply take a short piece of wire and temporarily jumper the tip side (CO ground) to the ground connector on the protector block. By clamping around this jumper wire, you will now test the ground resistance potential including all terminations at this location. The return signal path required for the clamp-on ground tester to make this measurement will be the CO ground.

Overhead Telephone Distribution

Telephone systems delivered on overhead poles must also be bonded to the MGN. This is typically performed by supplying a No. 6 copper wire connected to the grounding strand above telephone space. If power is not supplied on these poles, driven ground rods must be installed at required pole intervals and subsequently tested.

Note: Coil wire for attachment to power company MGN

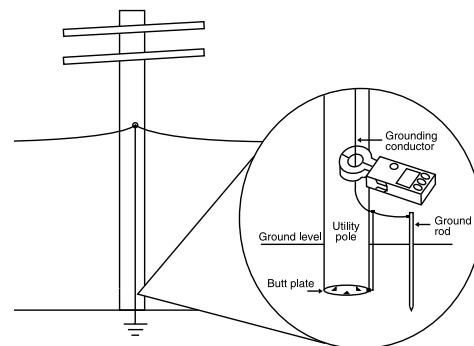
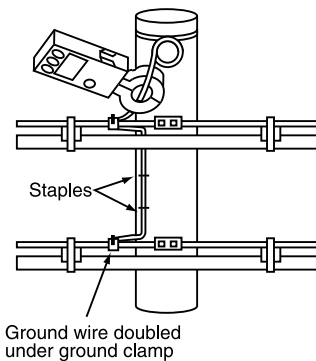

GROUNDING STRAND WITH NO OVERHEAD POWER

FIGURE 42

Summary Quiz

- When using the simplified Wenner formula ($\rho = 2\pi AR$) for determining soil resistivity, four-pole electrode depth should be:
 - 1/2 of the electrode spacing
 - 1/20 of the electrode spacing
 - 2 times the electrode spacing
 - equal to the electrode spacing
- What factors determine soil resistivity?
 - Soil type
 - Amount of moisture in soil
 - Amount of electrolytes in soil
 - Temperature
 - All of the above
- When doing a soil resistivity test and placing auxiliary rods at a spacing of 15 feet, what depth of earth is being measured?
 - 7.5 feet
 - 15 feet
 - 30 feet
 - 60 feet
- What results can be obtained by doing a soil resistivity measurement?
 - Geophysical surveys
 - Corrosion analysis
 - Electrical grounding design
 - All of the above
- As the temperature of the soil decreases, what happens to the soil resistance?
 - Decreases
 - Increases
 - No change
- Doubling the diameter of the rod has what effect on the potential resistance of a ground rod to be installed?
 - 100% reduction
 - 50% reduction
 - 25% reduction
 - Less than a 10% reduction
- As a general rule, doubling the depth of the rod length reduces the resistance by:
 - 100%
 - 40%
 - less than 10%
- What is the most important reason for good grounding practices?
 - Proper operation of electrical equipment
 - Safety
 - Meet National Electrical Code® requirements
- If a 5/8-inch ground rod is supposed to measure 25 Ω and the local soil resistivity measures 20 k Ω -cm, approximately how deep must the rod be driven?
 - 10 feet
 - 25 feet
 - 40 feet
 - 50 feet
- Fall-of-potential ground resistance measurements are recommended when:
 - the ground under test can be conveniently disconnected
 - ground faults are likely to occur near the ground under test
 - the power system cannot be shut down

-
11. When performing fall-of-potential tests, the ground electrode should be:
 - a. in service and energized
 - b. disconnected and de-energized
 - c. it makes no difference
 12. What is the minimum number of measurements needed to accurately perform a fall-of-potential test?
 - a. 1
 - b. 2
 - c. 3
 - d. 5
 13. If when making a fall-of-potential test each test result is significantly different in value from previous measurements on the same rod, what corrective action should be attempted?
 - a. Position the Z electrode farther from the rod under test
 - b. Position the Z electrode closer to the rod under test
 14. What is the maximum ground resistance required by the National Electrical Code®?
 - a. 5Ω
 - b. 15Ω
 - c. 25Ω
 - d. 1Ω
 15. When testing a multiple electrode grid, auxiliary electrode spacing is determined by:
 - a. depth of the deepest rod
 - b. maximum internal grid dimension
 - c. the VA rating of equipment being grounded
 16. Touch potential measurements are recommended when:
 - a. it is physically impossible to disconnect the subject ground from service
 - b. determining the degree of electrical safety under fault conditions is considered to be more important than measuring actual ground resistance
 - c. the grounding system is extensive and undocumented
 - d. all of the above
 17. The clamp-on test method cannot be used on high tension towers due to their spacing.
 - a. True
 - b. False
 18. The clamp-on tester must be clamped around the ground rod only.
 - a. True
 - b. False
 19. The clamp-on tester can be used only if the system under test is energized.
 - a. True
 - b. False
 20. The clamp-on method of testing should not be performed:
 - a. when testing large substation grounds
 - b. on ground electrodes disconnected from service
 - c. on single-point, lightning protection grounds
 - d. All of the above

References

IEEE Std 81-1983

— *IEEE Guide for Measuring Earth Resistivity, Ground Impedance, and Earth Surface Potentials of Ground Systems*

IEEE Std 142-1982

— *IEEE Recommended Practice for Grounding of Industrial and Commercial Power Systems*

Blackburn/American Electric Co.

Memphis, TN 38119

— *A Modern Approach to Grounding Systems*

Grounding Nomograph

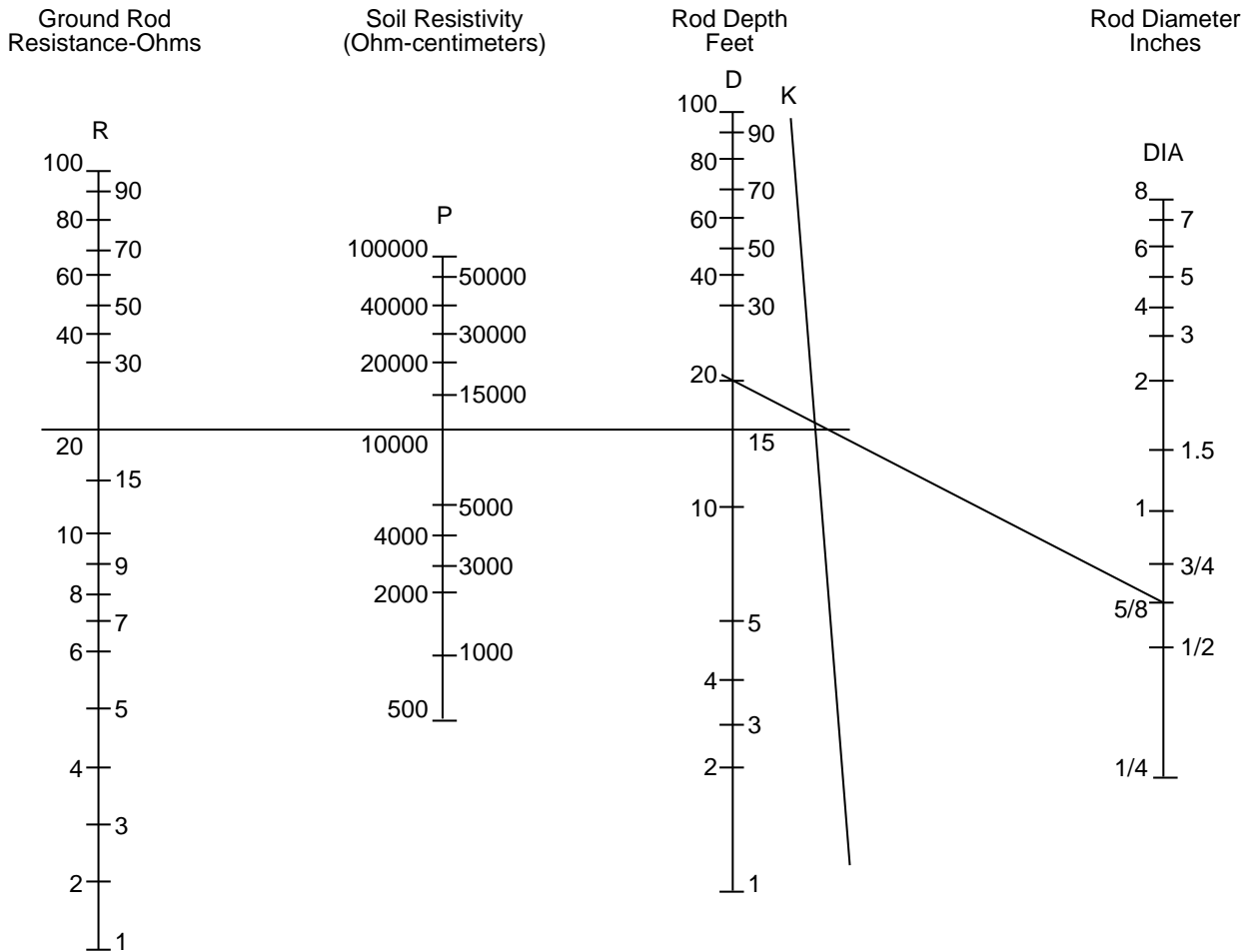

Represents example of a 20Ω , 20-foot ground rod.

1. Select required resistance on R scale.
2. Select apparent resistivity on P scale.
3. Lay straightedge on R and P scale, and allow to intersect with K scale.
4. Mark K scale point.
5. Lay straightedge on K scale point and DIA scale, and allow to intersect with D scale.
6. Point on D scale will be the rod depth required for resistance on R scale.

